

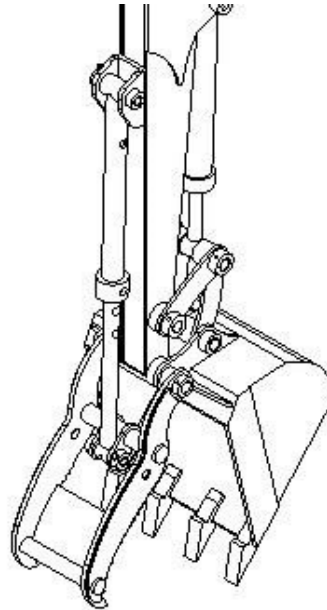

MIE BT85-SHP

Shared Pivot Pin Backhoe Thumb

KIOTI KB2485 Backhoes



Owner's Manual / Installation Instructions

Rev. 2.2 – SN BT85SHP-A117~

Table of Contents

Section 1.1 - Safety	3
Section 1.2 - Specifications	4
Section 2.1 - Thumb Installation	7
Section 2.2 – Backhoe Thumb Usage	15
Section 2.3 – Storing Thumb	16
Section 3.1 – Thumb Maintenance	18
Section 3.2 – Warranty	19
Section 3.3 – Product Information	20
Section 4.1 – Parts Diagrams / Parts Lists	21-23

Section 1.1 – Safety

Thumb Capacities:

Max Bucket Breakout Force:

4000 LBS

Recommended Backhoe Models:

KIOTI KB2485

TYM BT400

LS LB3100

Never exceed the maximum thumb capacities listed above.

Always lower the backhoe stabilizers when lifting objects with a thumb, machine tip-over or in-stability can occur otherwise.

Keep hands, feet, arms, and loose clothing clear of the thumb / bucket and all other moving parts at all times. Failure to stay clear of moving parts can lead to serious injury and/or death.

Assure all pins and hydraulic connections are secure and leak free before each use.

Never stand under a lifted load. Always keep children away while operating the thumb / backhoe.

Wear safety glasses and protective clothing while operating the backhoe with a thumb.

Hydraulic fluid under pressure can cause serious injury if allowed to contact skin. Check for hydraulic leaks using a clean piece of cardboard and heavy work gloves.

Failure to follow the safety instructions contained above could cause serious damage to your tractor, backhoe, the attachment, and injury or death.

Always take care when pushing on an object such as a tree or building with a backhoe. Objects such as tree limbs / branches or siding or framing have the potential to “snap” back towards the operator platform of the machine which could cause in serious injury or death.

Section 1.2 – Specifications

BT85-SHP SPECIFICATIONS	
MAX BUCKET BREAK-OUT	4,000 LBS
TYPICAL MAX MACHINE WEIGHT	N/A
THUMB WEIGHT (MECHANICAL)	92 LBS
THUMB WEIGHT (HYDRAULIC)	105 lbs
THUMB LENGTH	23"
THUMB WIDTH (O/O)	9 ½"
MAIN PIVOT PIN DIAMETER	32 mm
POSITIONING PIN DIAMETER	1 3/4"
POSITIONING PIVOT PIN DIAMETER	7/8"
MAIN PIVOT PIN GREASE-ABLE	YES
THUMB TINE MATERIAL	1/2" AR235
NO. THUMB TINES	2
NO. POSITIONS (MECHANICAL)	4
STORAGE POSITION	YES

BT85-SHP Mechanical Thumb Positions - Dimensions

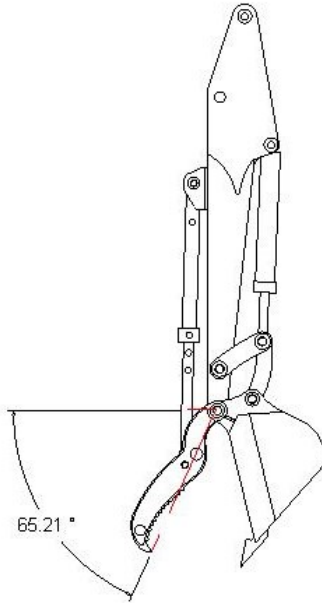

Thumb Position A1

Figure 1 BT85-SHP Thumb Position A1

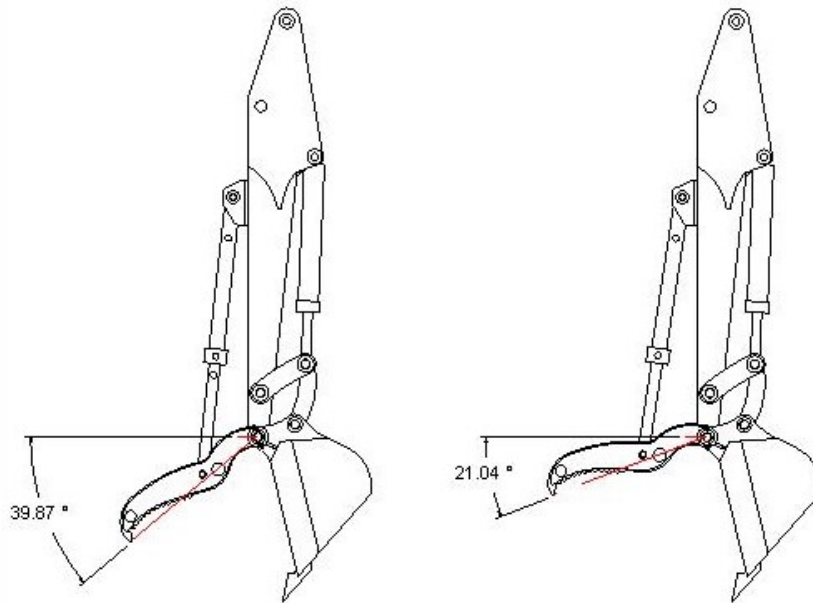

Thumb Position A2

Thumb Position A3

Figure 2 BT85-SHP Thumb Positions A2 and A3

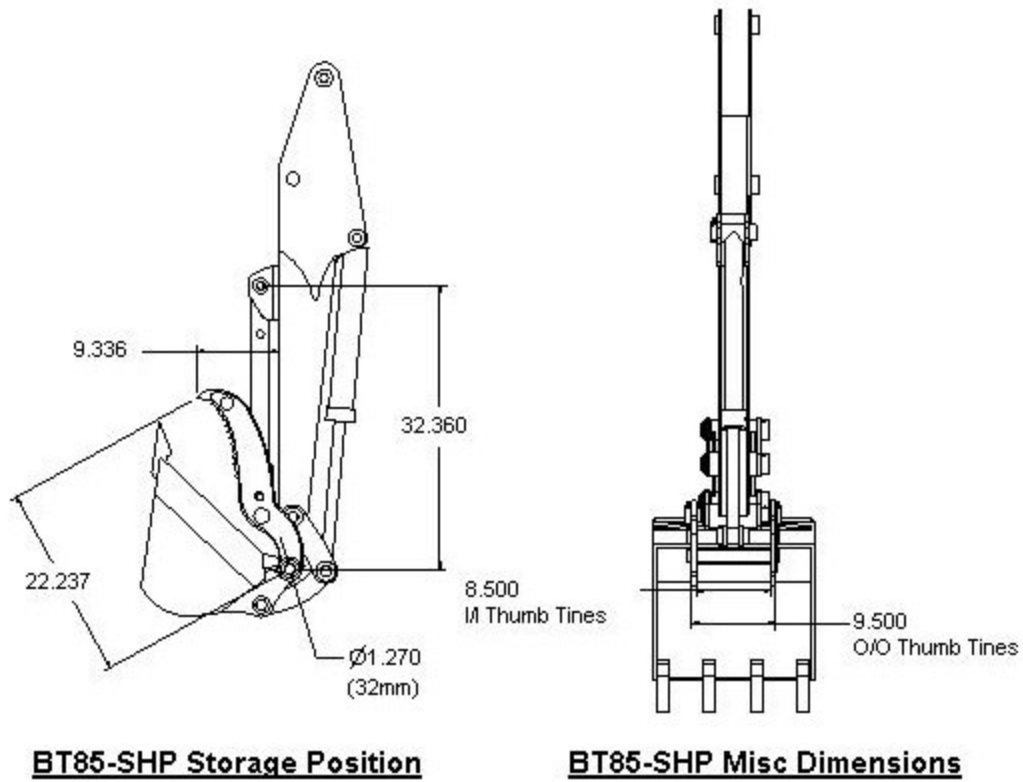

Figure 3 BT85-SHP Storage Position and Thumb Width Information

Section 2.1 – Thumb Installation

Mechanical and Hydraulic Models

Step 1

- Remove Bucket Main Pivot Pin Located at the Bottom of the Backhoe Dipper Stick by Removing the M10 Keeper Bolt from the LHS Bucket Pin Bushing and Tapping the Pin Out.
- Pin the BT85-SHP Backhoe Thumb onto the Bucket Main Pin Using the New 32 MM Pin Supplied.
- Re-Insert the M10 Keeper Bolt from the Original Bucket Pin and Tighten.

Step 2

- Pin the Rod End of the Positioning Link or the Hydraulic Cylinder into the Clevis on the Thumb using the 1” Pin Supplied.
- Pin the Base End of the Mechanical or Hydraulic Cylinder into the Cylinder Mount that will be welded to the Dipper Stick. Be sure the Cylinder is in the Fully Collapsed Position and Fold the Thumb, Cylinder, and Base toward the Dipper Stick. The Center of the Pin in the Base Should be approximately 32 3/8” from the center of the Main Bucket / Thumb Pivot Pin.
- Mark the Position of the Base on the Dipper Stick and Fold the Thumb Back Down Toward the Bucket. See also Figure 4 for Aid in Locating the Cylinder Base on the Backhoe Dipper Stick.

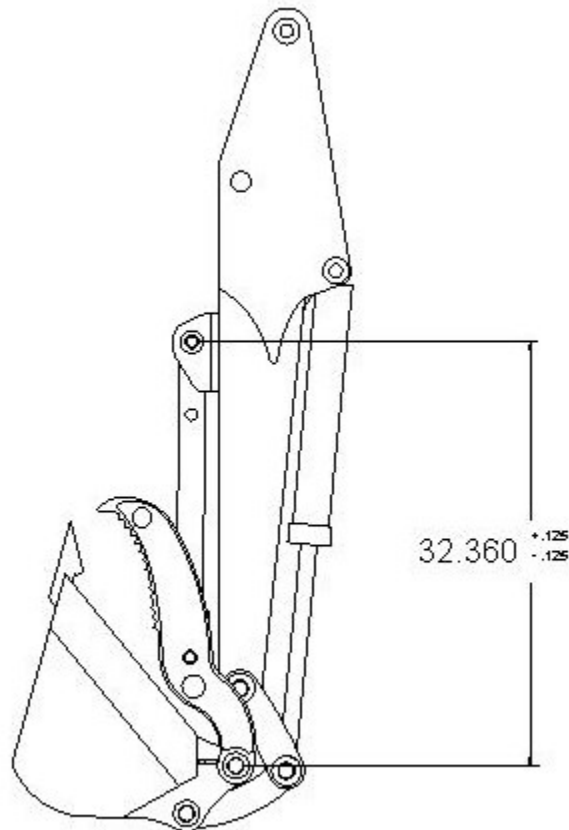
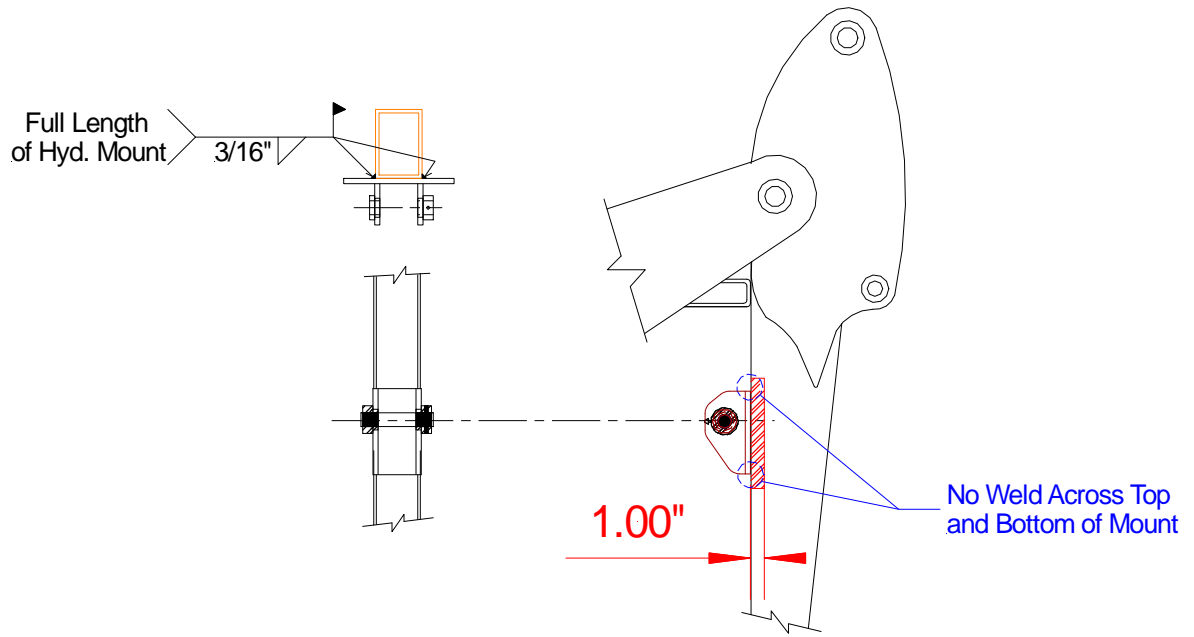

Figure 4 Position of Cylinder Base on Dipper Stick for Both Mechanical and Hydraulic Models.

- Prepare The Back of the Cylinder Base and the Dipper Stick for Welding by Sanding the Surfaces until Bare Metal is exposed. There should not be paint within 1” of Any Area that is to be welded. It is very Important to Ensure there is no Paint Left on Either Surface to Ensure the Welds are not Contaminated which can lead to Weld Failure.
- Consult the Voltage and Wire Feed Guide on your Welding Machine to Determine what these Settings should be for the Application.
- See Figure 5 Below for Welding Instructions and Procedure. If this Procedure is not Followed Correctly all **Warranties will be Void.**
- **It is highly recommended to “Tack” the thumb onto the dipper stick and check again for clearances with the bucket curled all the way in before fully welding the base.**
- Once the cylinder mount has been tacked into place, un-pin the base end of the cylinder from the mount for full welding.



Dipper Stick Cylinder Mount

Figure 5 Welding Procedure for Cylinder Base Mount

- Once the welds have cooled paint touch up can be done on the dipper stick and cylinder mount.
- Pin the base end of the cylinder into the mount and secure the pin with the supplied 5/16" x 2 1/2" bolt and corresponding hardware.
- Installation for Mechanical Models is Complete, for Hydraulic Units please continue on to Step 3.

Step 3

- Locate the Thumb Control Valve Mounting Template. Lay the Template on the Floorboard of the Operator Platform as Shown in Figure 6.
- Holes A-C should be Drilled to 11/32" and Hole D should be Drill to 1 1/4".

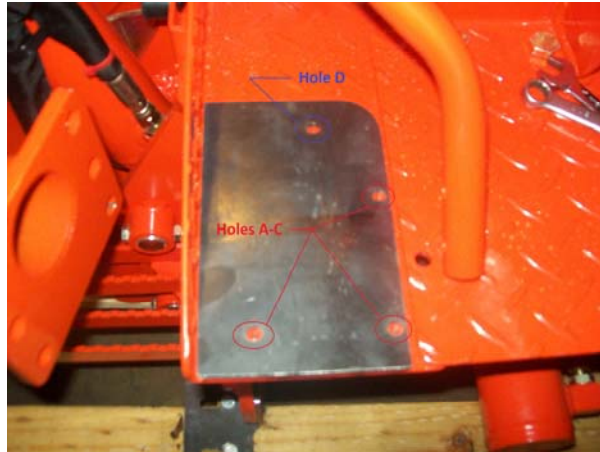

Figure 6 Valve Mount Pattern on LHS Floorboard of Operator Platform.

- Turn the Bolt for the Backhoe Brace to Face Outward. The Rotation Stop on the Brace will need to be cut off in order to do this.
- Once the Bolt has been Faced Outward and Re-Tightened, Bolt the Control Valve to the Bottom Side of the Operator Platform Using the (3) 5/16" x 3/4" Bolts Provided.
- Bolt the Foot Pedal to the Spool Stem Sticking out of the Platform Using the 8mm x 14mm Long Bolt Provided.



Figure 7 Foot Pedal Installed on LHS of Operator Platform.

Step 4 – Thumb Control Valve Power Connection

- Plug the Red Coded Hydraulic Line from the Backhoe into the ½” Female Quick Coupler on the Thumb Control Valve.
- The Blue Coded Hydraulic Line From the Control Valve should then be Plugged into the “A” Port on the Tractor Rear Remote.
- The White Coded Hydraulic Line Should be plugged into the “B” Port of the Tractor Rear Remote.
- Once the Three Connections have been Made, Move the Rear Remote Control Lever in the “A Position” from the Tractor Operator Platform.

Step 5 – Connecting the Cylinder to the Control Valve

- Locate the 148” long hydraulic line color coded green. One end of the line will have a 45 degree hose end on it. Connect this end of the line to the LHS of the Hydraulic Cylinder as Show in Figure 8.

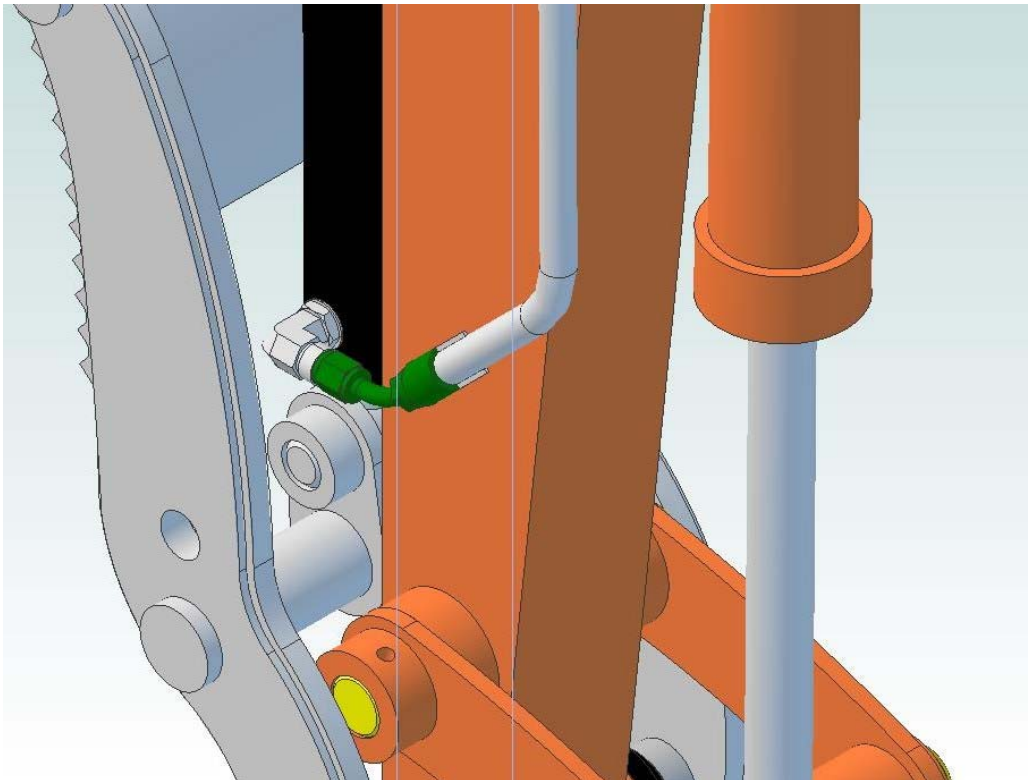

Figure 8 Green Hydraulic Line Connection at Hydraulic Cylinder.

- **Locate the 132” Long Hydraulic Line Color Coded White. Both Ends of this Line have a 90 Degree elbow fitting on them. Lay out the hydraulic line and note the orientation the two ends to each other. The elbows are rotated 90 degrees from each in order to keep the hose from twisting when making the connections at the cylinder and valve.**
- **Once sure of the orientation of the fittings, connect the white hydraulic line to the top of the cylinder on the RHS of the Backhoe.**

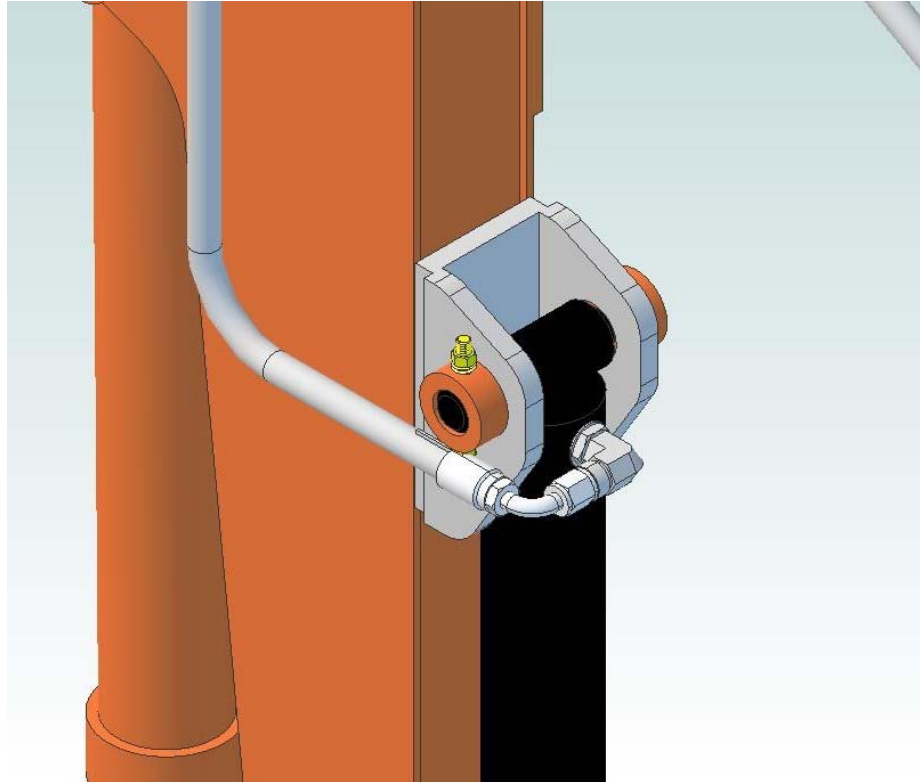

Figure 9 White Hydraulic Line Connection at Cylinder.

- **Locate the two Hose Guides and Mount them at the Top of Backhoe Boom. Loosen the Bulkhead Fitting for the Bucket Control Lines and Slide the Hose Guides between the Bulkhead Fitting and the Mounting Tab on the Boom.**



Figure 10 Hose Guides Mounted at the Top of the Backhoe Boom.

- **Route the Two Control Lines Down through the hose Guides and Down the Backhoe Boom. The Lines can either be Run Through the Boom with the other Backhoe Hydraulic Lines or along the Top of the Boom underneath the Dipper Stick and Boom Cylinders. At the Bottom of the Boom, be sure the Hoses are Going through the Main Backhoe Pivot Point with the other (6) existing Hydraulic Lines.**

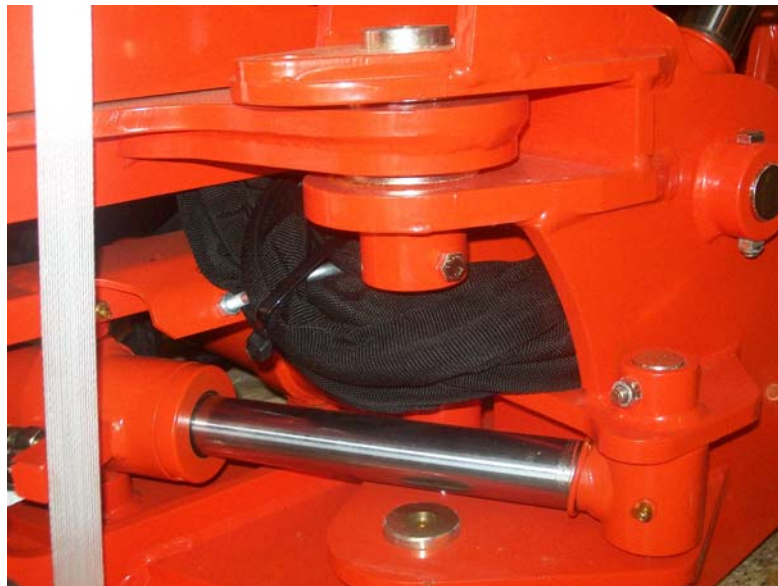
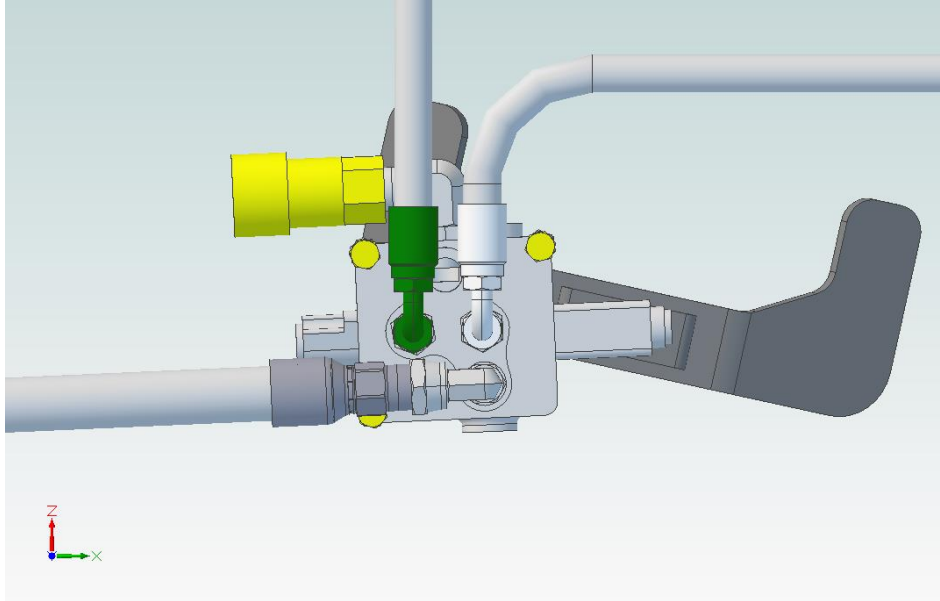

Figure 11 All Hoses Routed Through the Main Pivot Point of Backhoe Boom.

- Route the Lines Under the Operator Platform and connect the lines to the control valve following the connection diagrams below.



Figures 12 – 13 Connection Locations / Color Coding for Thumb Control Lines and Valve.

STEP 6 – Finalizing Installation

- Start the Tractor and Slowly Push the Control Pedal Forward. Rotate the Thumb all the Way Down and then Pull Back on the Pedal to Retract the Thumb into the Storage Position. Cycle the Thumb 3-4 Times Slowly and then Check for Leaks.
- Grease all (7) grease fitting locations before use. See Section the Maintenance Section 3.1 for grease fitting locations.

Section 2.2 – BT85-SHP Usage

The Designed Function of a Backhoe Thumb is to Aide in Lifting and Moving Objects in Correlation with the Backhoe Bucket. Always Curl the Bucket into the Thumb, Moving the Object towards the Thumb. **An Object should Never be Dug out of the Ground with the Backhoe Thumb.**

Always put the thumb in the storage position when it is not being used. This will prevent damage to the thumb in normal digging operations. Never “side-load” a thumb by swinging the backhoe boom side to side into an object or the ground. The thumb has not been designed to handle large side loads.

Always center the object or load on the thumb as much as possible to minimize torque on the thumb.

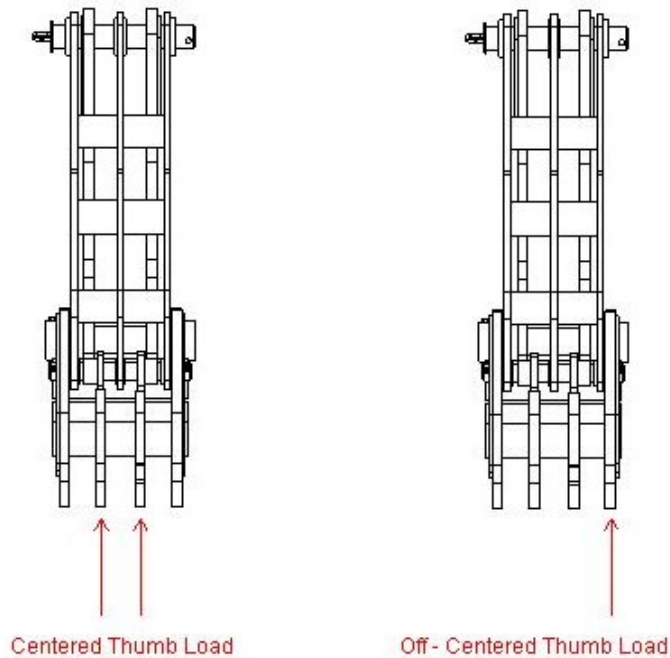

Section 2.3 – BT85-SHP Storage

When the Backhoe Thumb is not being Used it can be Folded up into the Storage Position on the Dipper Stick as Opposed to Removing the Thumb From the Backhoe completely. It is Highly Recommended to Put the Thumb in the Storage Position when it is not being Used.

- For Mechanical Models: Remove the Positioning Pin from the Positioning Link and Fold the Thumb Towards the Dipper Stick. Slide the Pin Back through the Top Hole in the Link Base when the Thumb is Tight Against the Dipper Stick as Shown Below.

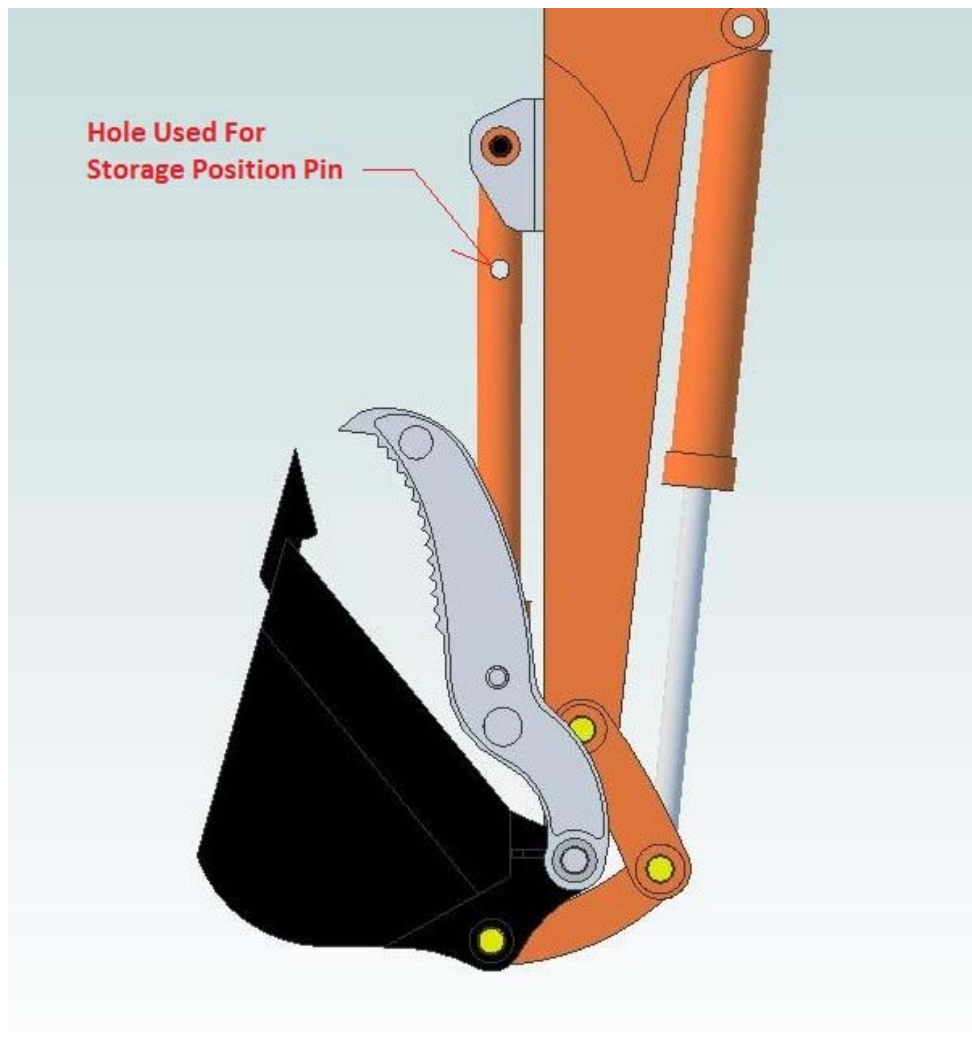

Figure 14 Storage Position for Mechanical Thumbs

- For Hydraulic Models: Press Back on the Control Pedal and Allow the Thumb to Rotate Against the Dipper Stick until it Stops. Once the Thumb Stops, Return the Pedal to the Neutral Position.

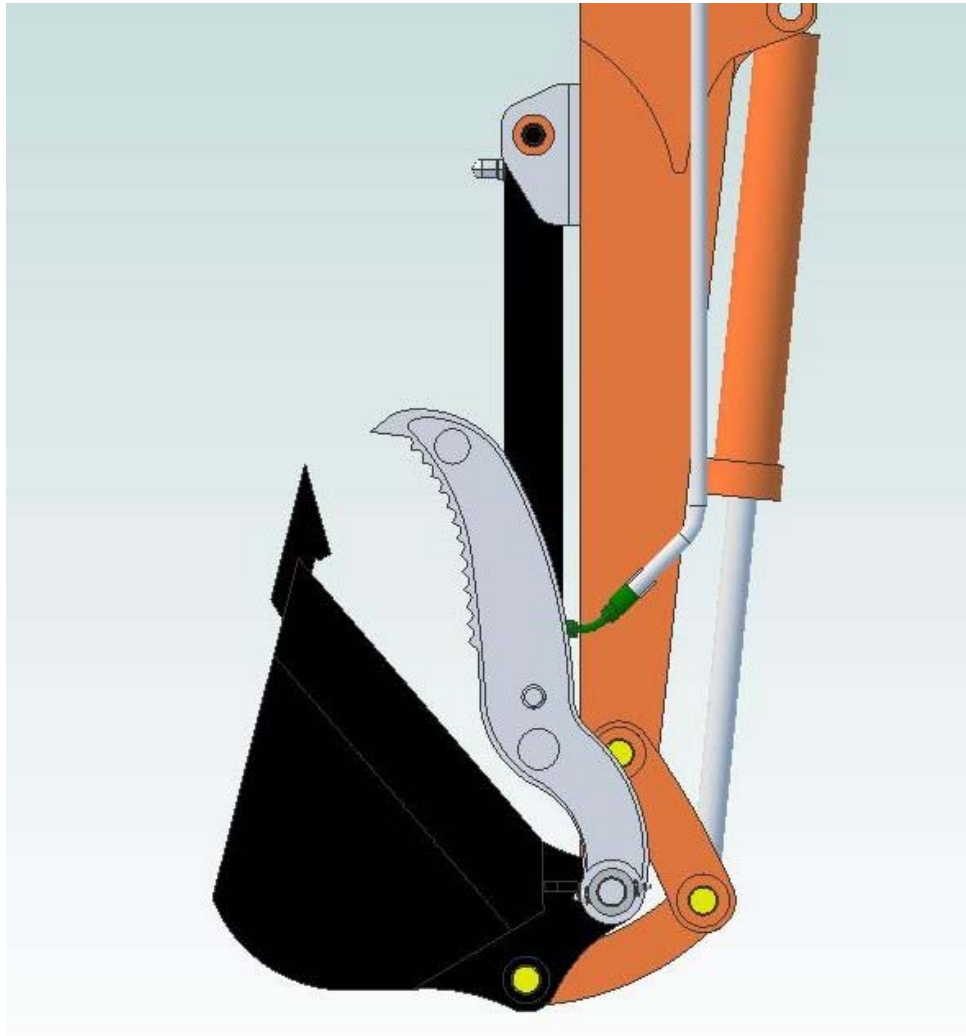

Figure 15 Storage Position for Hydraulic Thumbs

Section 3.1 – Maintenance

The BT85-SHP is equipped with (5) grease fitting locations for mechanical models and (7) grease fitting locations on hydraulic models. All models contain (2) fittings on each of the main pivot pin bushings and on the end of the pivot pin. Hydraulic models also contain a fitting on each end of the hydraulic cylinder. Be sure to grease these bushings every 10 hours of use to assure maximum life of the bushings and pins.

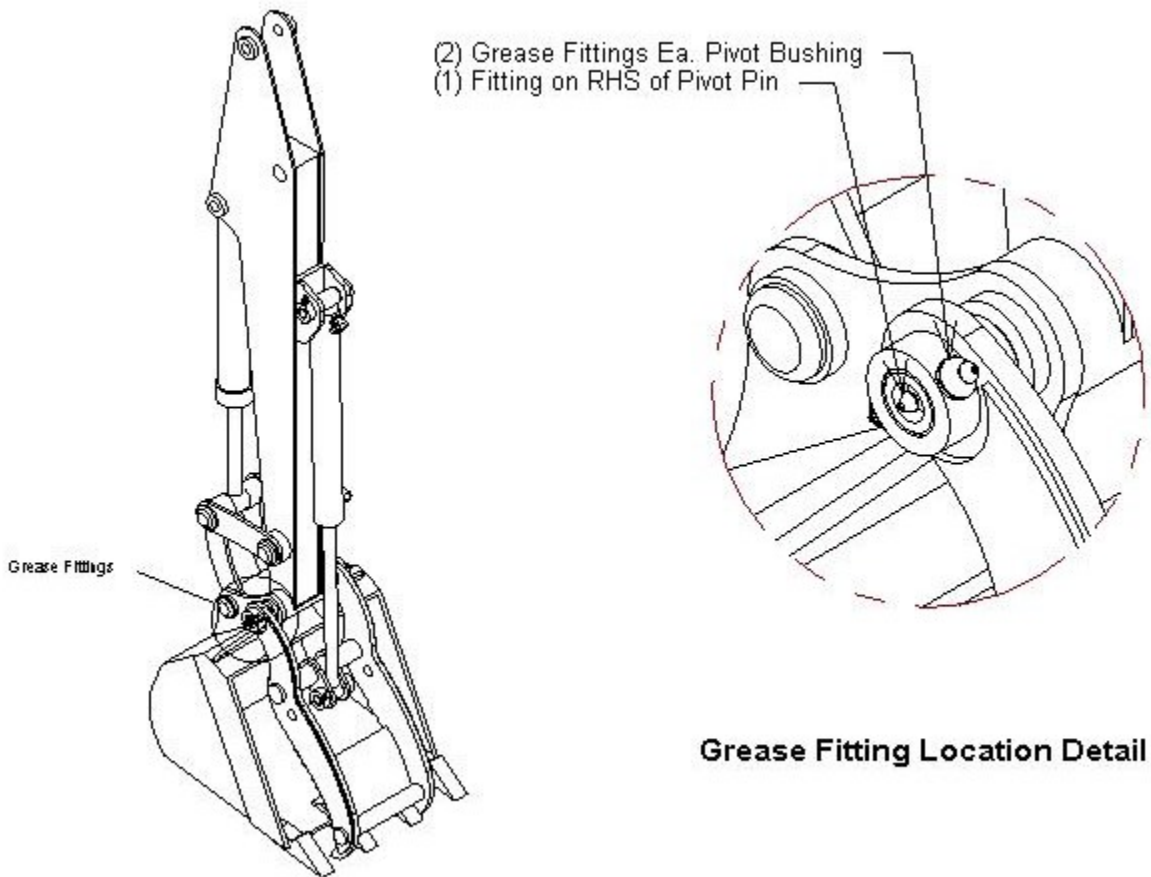

Figure 16 Grease Fitting Locations on BT-SHP Series Thumbs

Section 3.2 - Warranty

Michigan Iron and Equipment, LLC offers the original purchaser a 2-year Limited Warranty against defects and workmanship. If for any reason, you experience a Warranty covered problem with your BT85-SHP equipment during the MIE warranty period, Michigan Iron and Equipment will replace at no cost to the purchaser any part or parts found to be defective, except as outlined below. Our Warranty program includes delivery costs and shipping costs for owner installed replacement parts. This warranty is offered by Michigan Iron and Equipment, LLC and is independent of any programs offered by any of Michigan Iron and Equipment's suppliers or agents. The buyer by the acceptance of this equipment agrees to hold Michigan Iron and Equipment, LLC harmless from all other liability for any damages arising out of the use or misuse by the owner, it's employees, or others.

Backhoe Thumb Usage:

This Backhoe Thumb has been designed to be used only in the manner described in this owner's manual. Use of the thumb for any other purpose, or in a manner inconsistent with the instructions contained herein will void all warranties to the purchaser or his agents.

- The BT85-SHP should Never be Used for Digging Purposes.
- The BT85-SHP Should not Dug into the Ground and Used to Reposition the Backhoe in Any Direction.

Wear parts not covered by Warranty:

None

Replacement Parts:

Michigan Iron and Equipment stocks a full line of replacement parts for your BT85-SHP Backhoe Thumb. If you should need any replacement parts, please contact us:

Michigan Iron and Equipment
10231 Rose Blvd.
Morrice, MI 48857

Local: (517) 625-4590
Toll Free: (855) 265-4590

Section 3.3 - Product Information

Model:

BT85-SHP

Serial Number:

BT85SHP-AXXX

Date of Manufacture:

XX/XX/XX

Section 3.4 – Parts Diagrams – Lists

Please See Next Page for Diagrams and Lists.